

1 WALL @ GRADE BEAM
N.T.S.

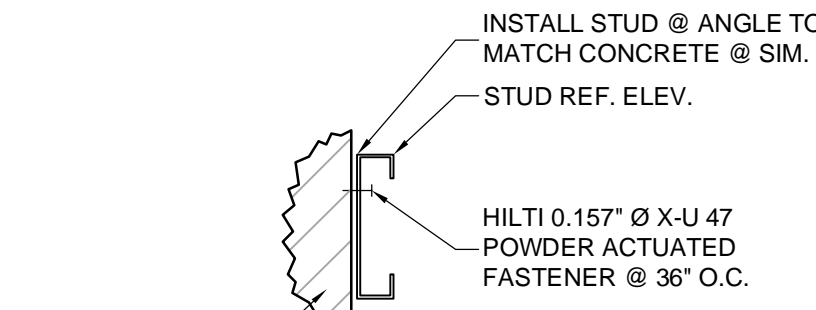

2 END OF WALL
N.T.S.

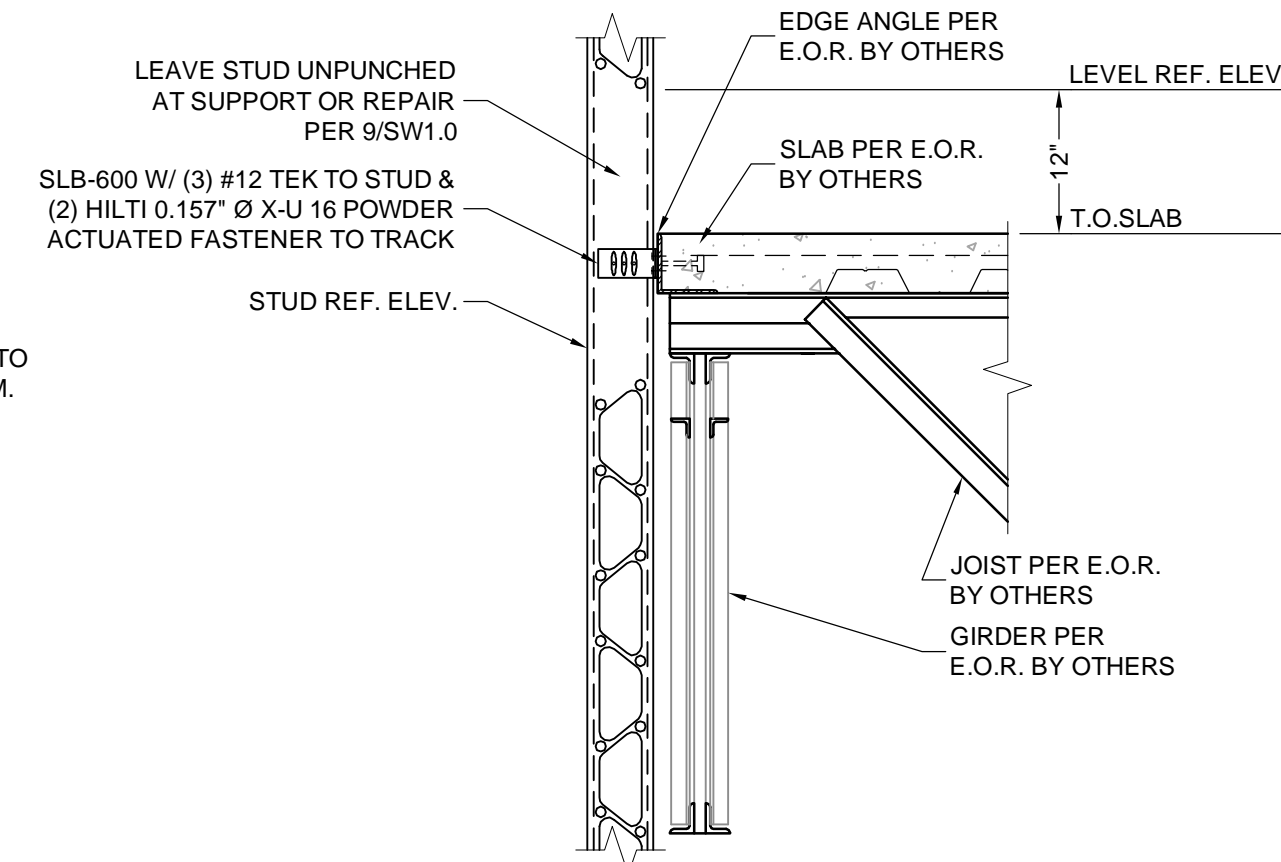

3 WALL @ GIRDER
N.T.S. 7/S-405

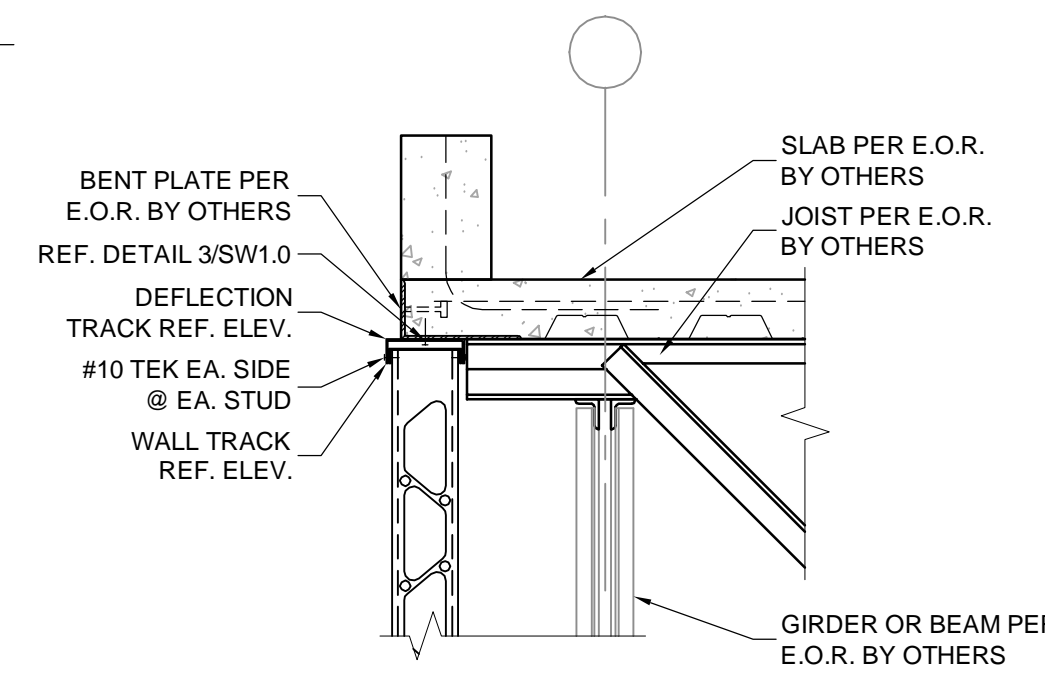

4 TRACK TO SLAB
N.T.S. 4/S-404

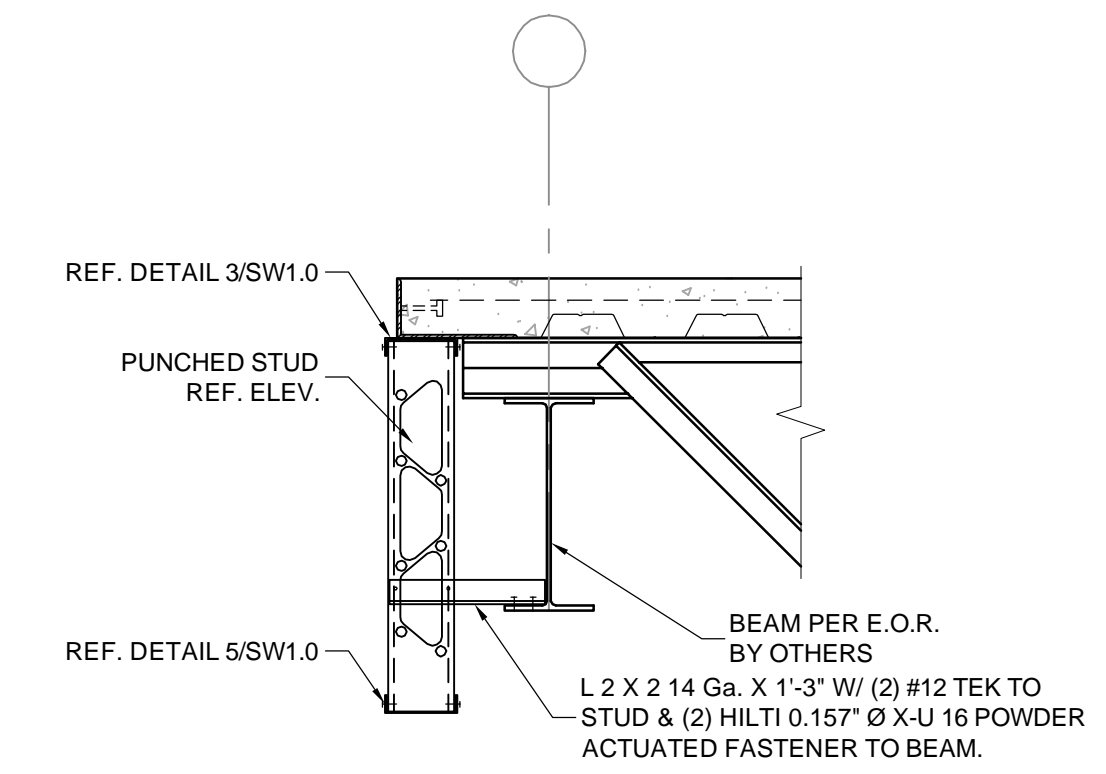

5 BALCONY @ BEAM
N.T.S. 2/S-302

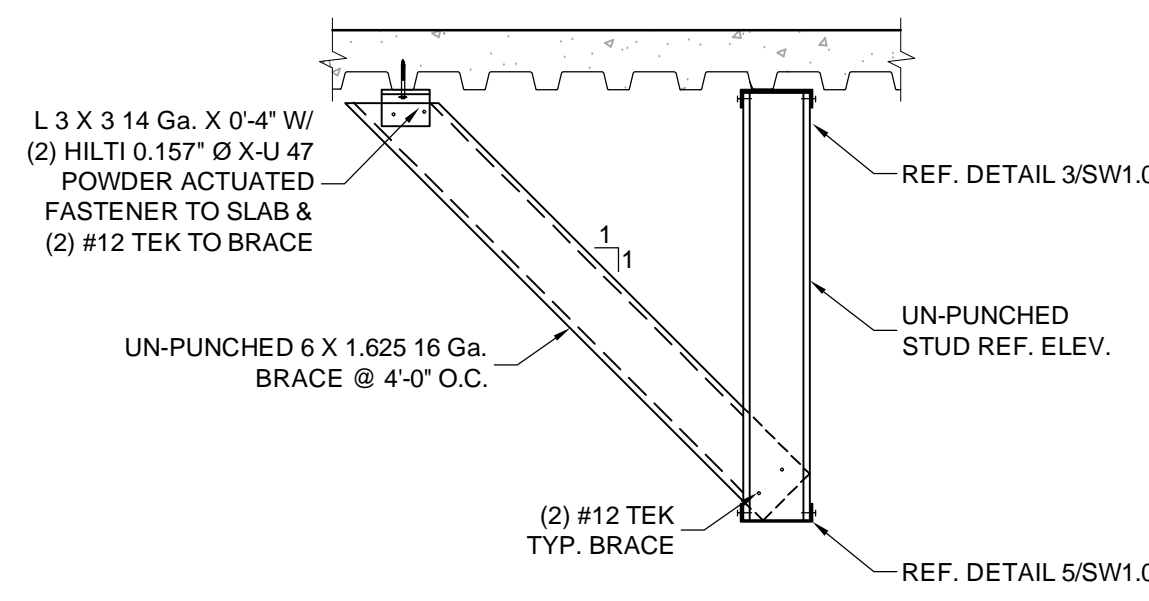

6 WALL W/ BRACE
N.T.S.

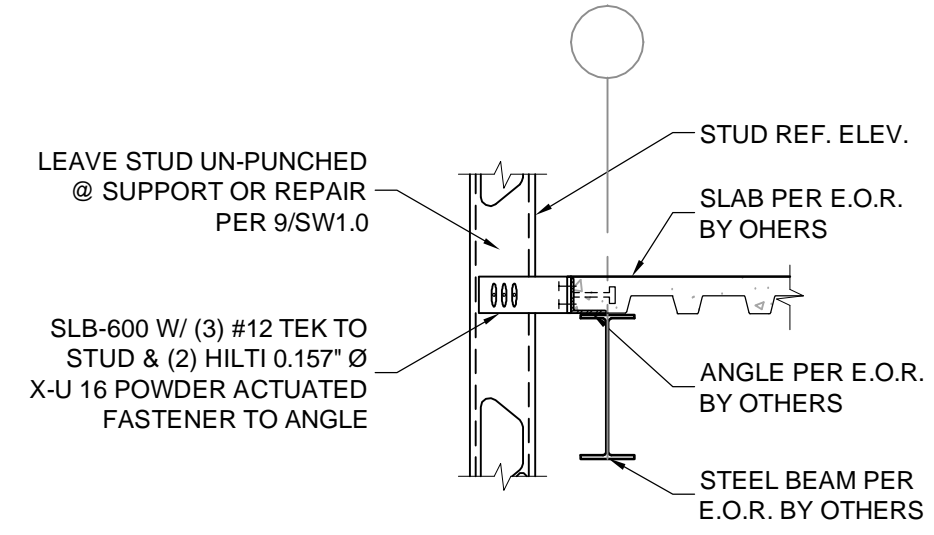

7 WALL TO FLOOR
N.T.S.

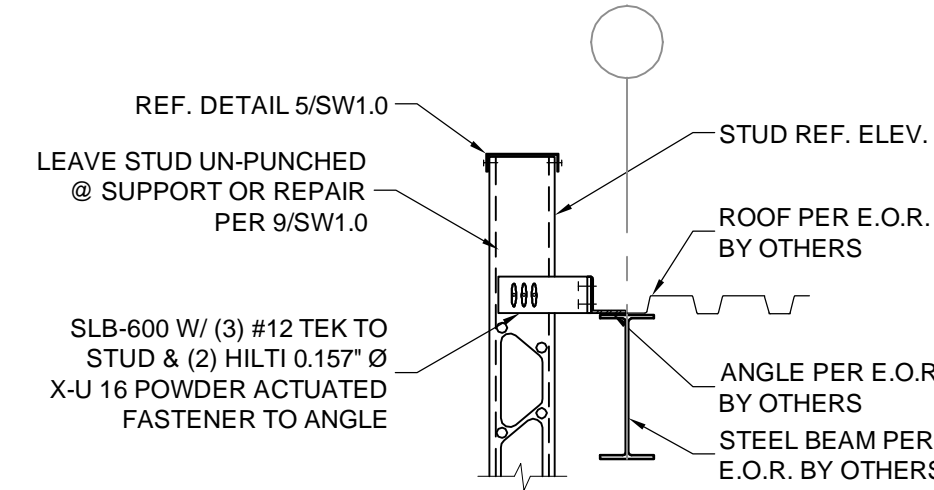

8 WALL TO ROOF
N.T.S.

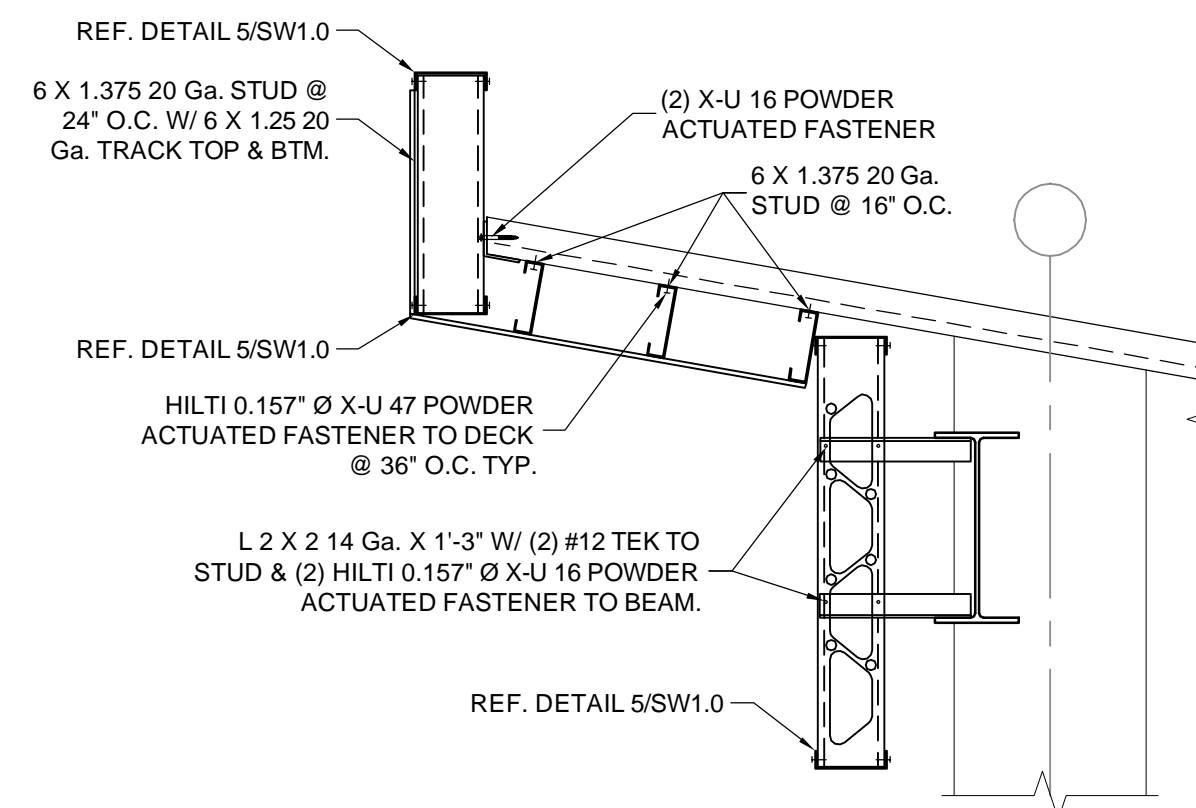

9 HIGH EAVE
N.T.S. 8/S-403

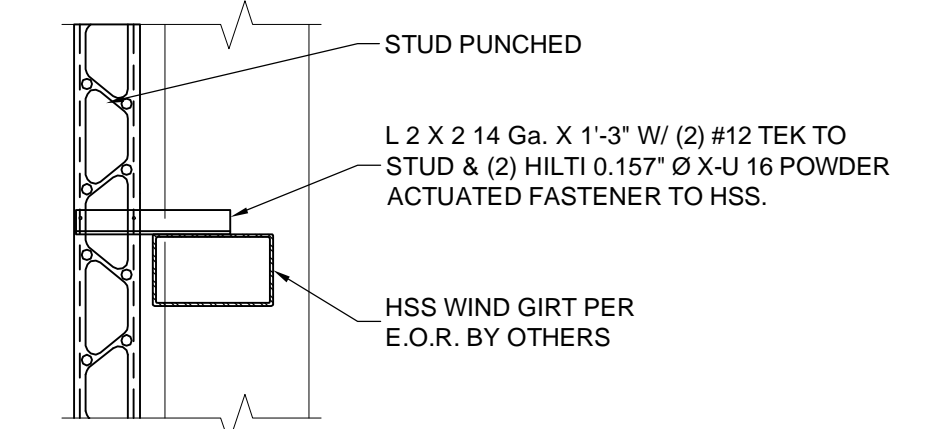

10 TYP. CONN. AT WIND GIRT
N.T.S. 5/S-006

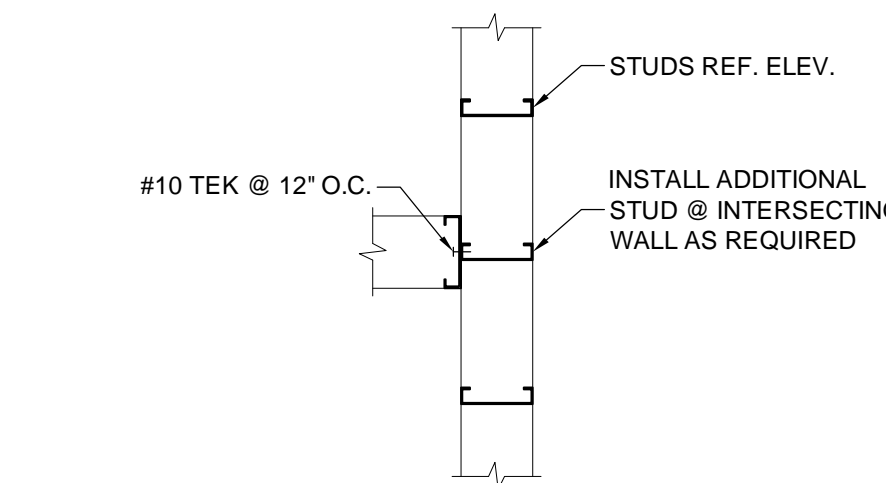

11 WALL INTERSECTION
N.T.S. 2/S-503

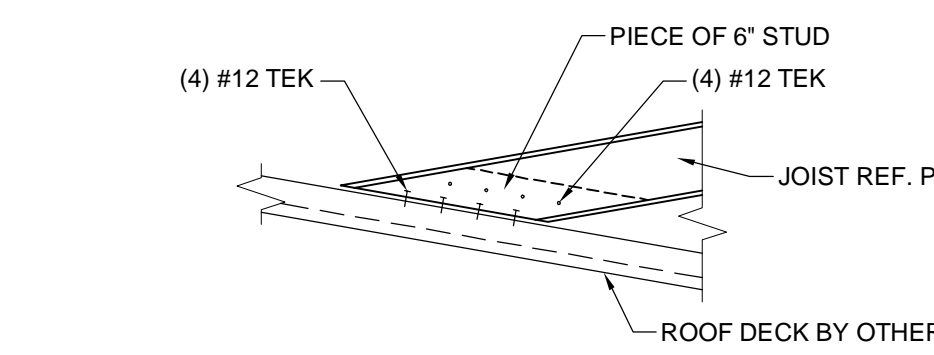

12 JOIST AT VALLEY
N.T.S.

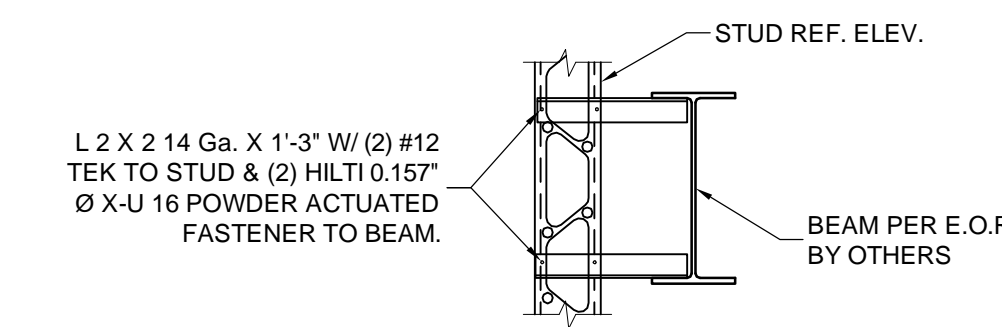

13 WALL TO BEAM
N.T.S. 2/S-503

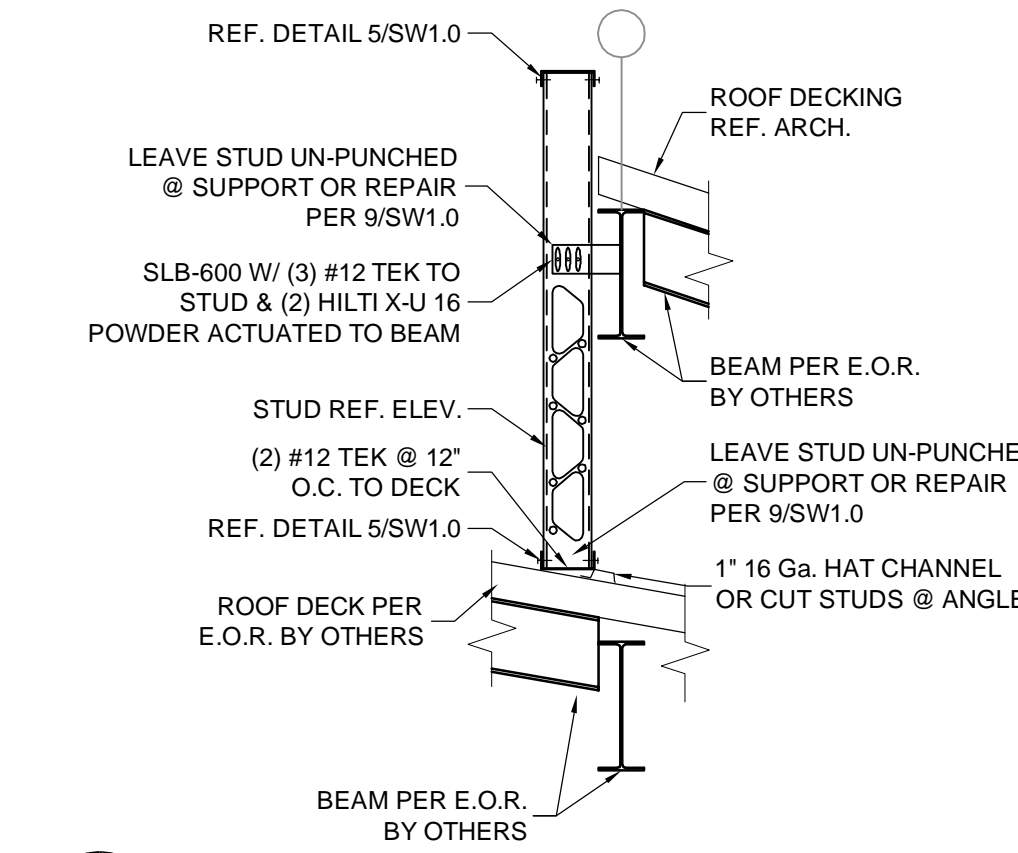

14 WALL @ SAW TOOTH
N.T.S. 13/S-405

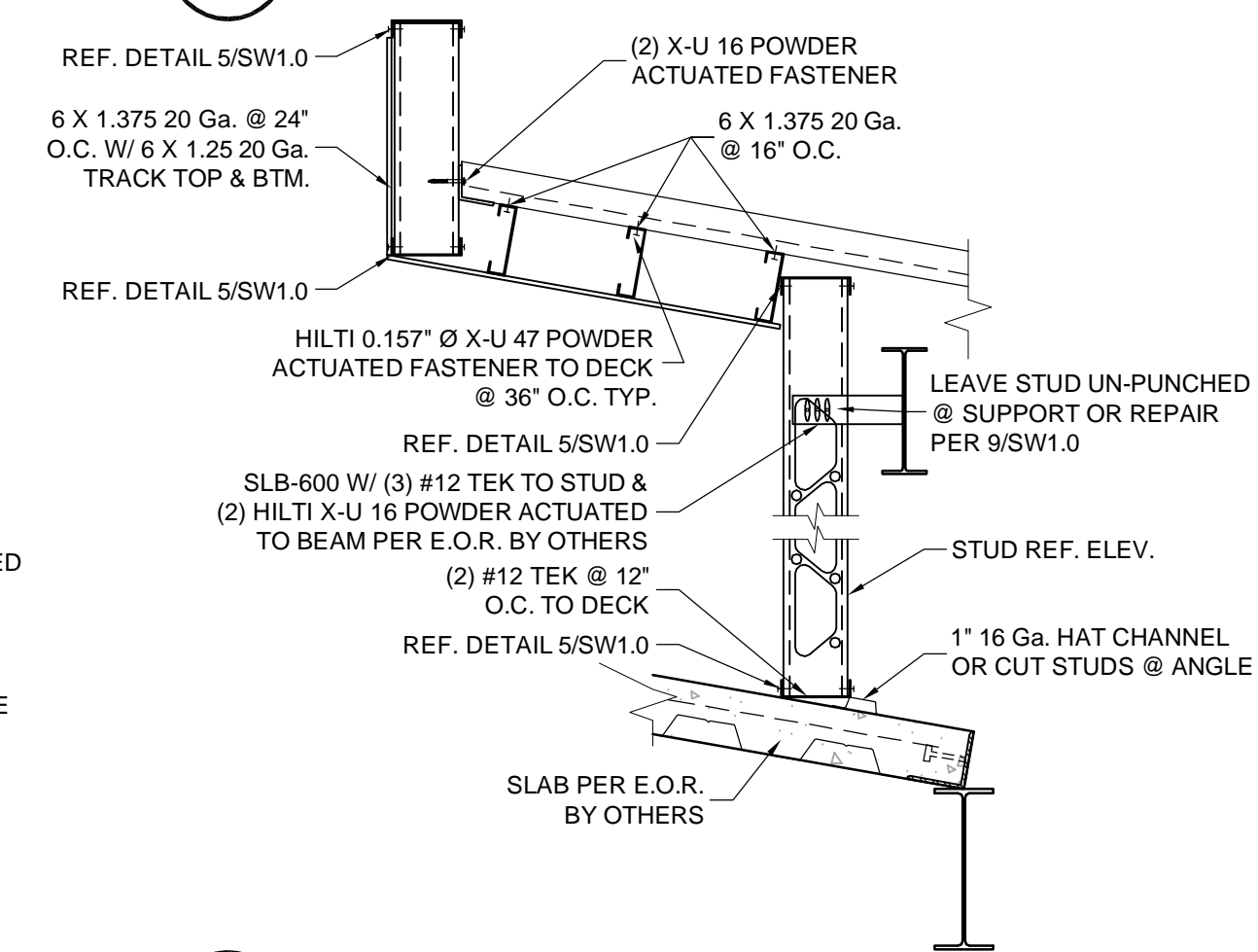

15 WALL ON ROOF
N.T.S.

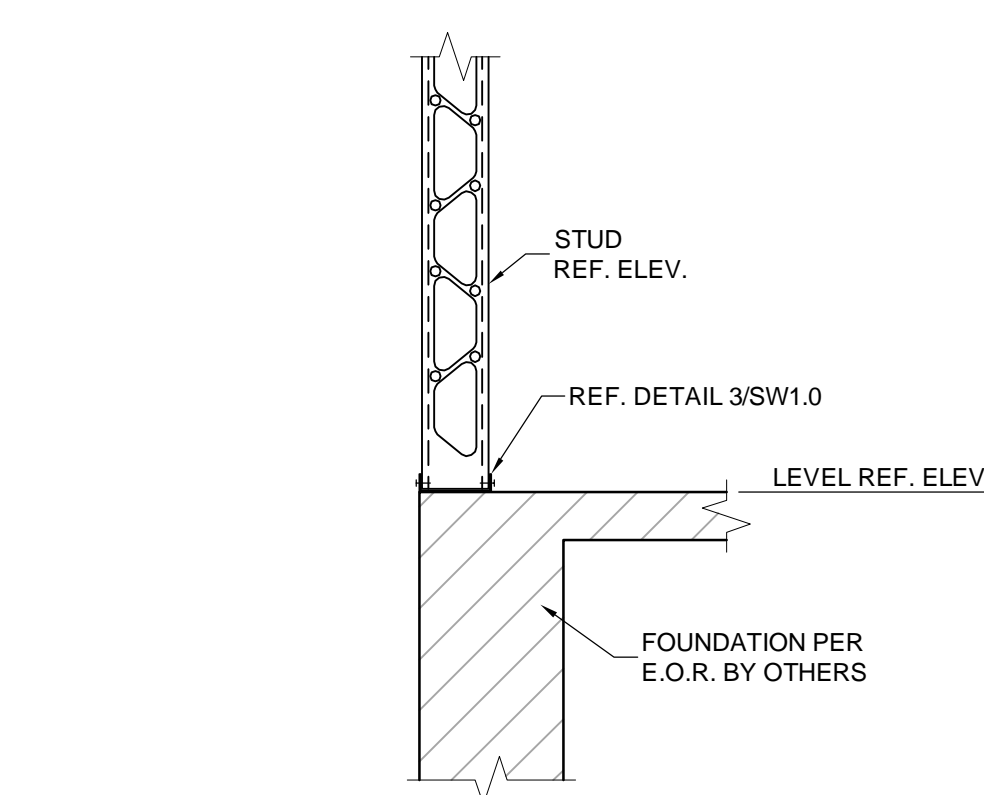

16 WALL TO FOUNDATION
N.T.S.

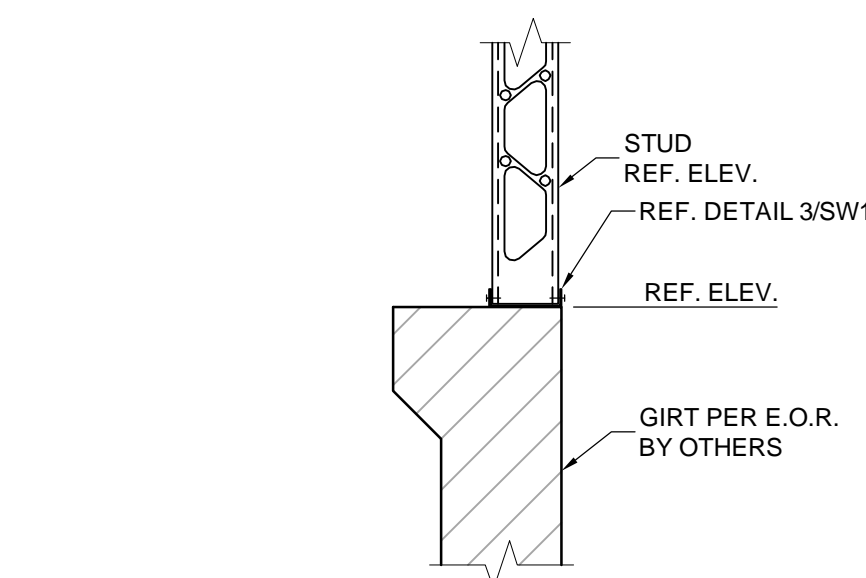

17 WALL TO GIRT
N.T.S.

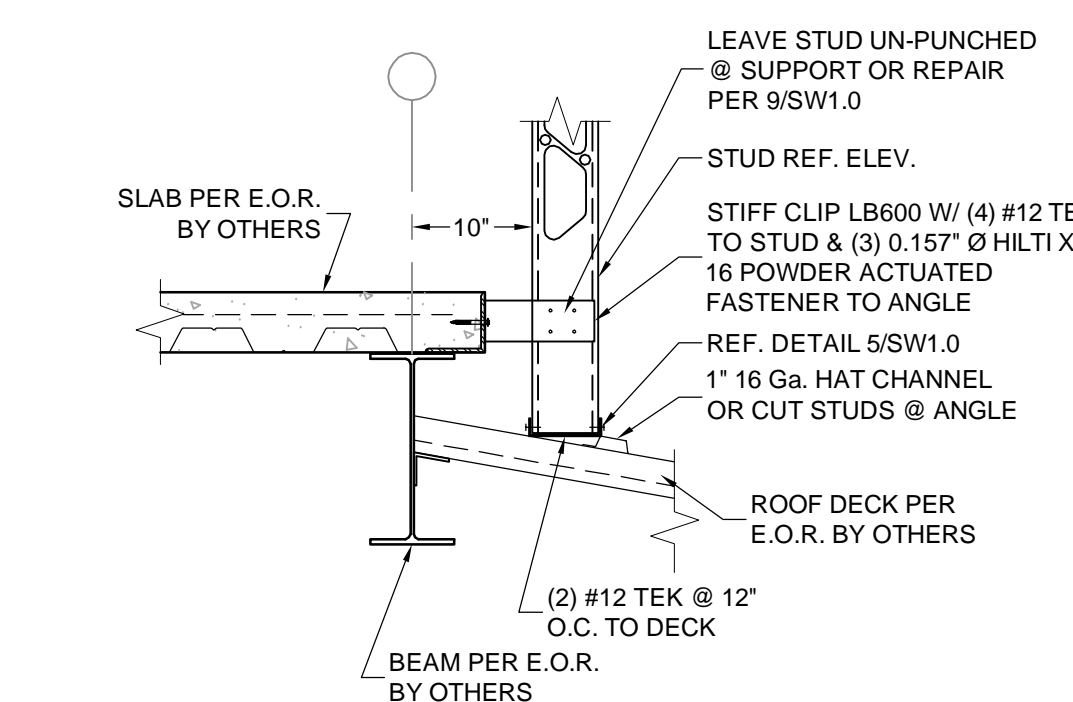

18 STUD TO DECK
N.T.S.

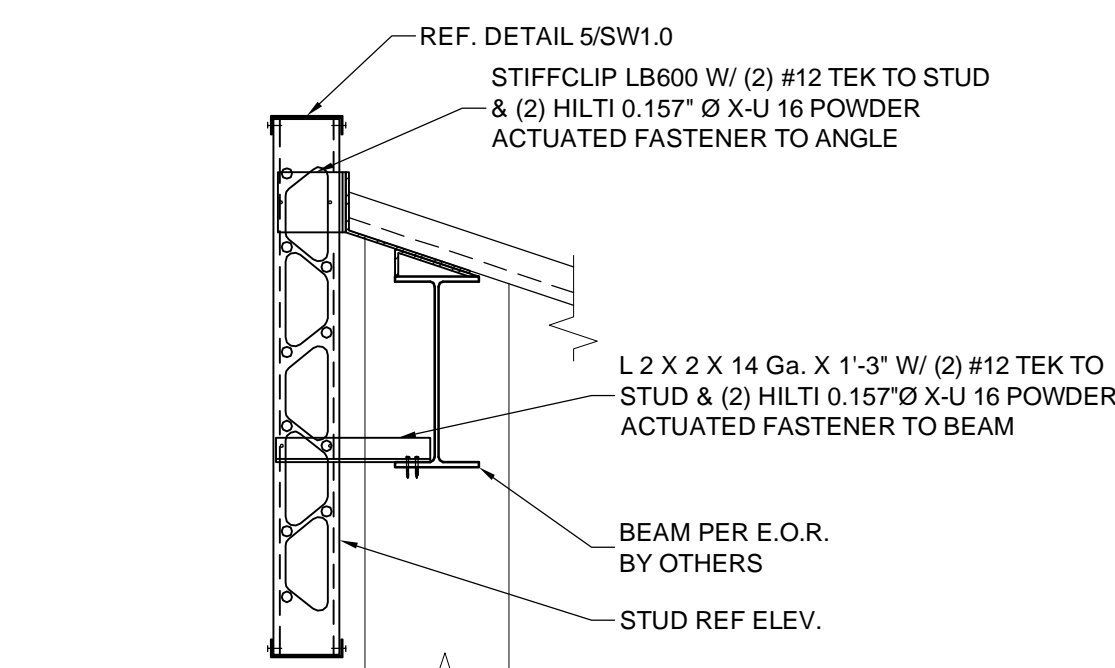

19 LIBRARY HIGH
N.T.S.

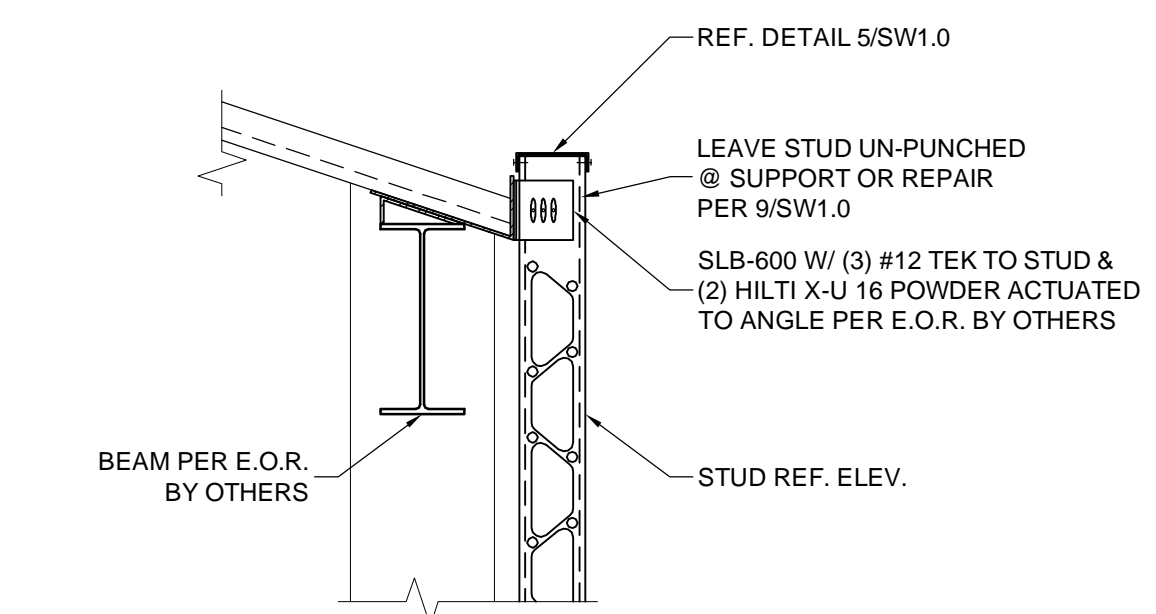

20 LIBRARY LOW
N.T.S.

6001 W. WILLIAM CANNON
BUILDING 2, SUITE 203-C
AUSTIN, TX 78749
(512) 301-3389 (o)
(512) 301-3348 (f)

TEXAS
DESIGN
INTERESTS, LLC
AUSTIN • HOUSTON

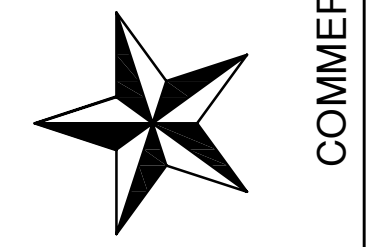

COMMERCIAL/RESIDENTIAL - CIVIL & STRUCTURAL ENGINEERING

GOLDEN, CO

DETAILS

PROJECT #
499-100

DATE
10/01/09

SHEET
SW2.0